

# MDT 860

## *User Manual*





# Contents

1	Introduction	5
1.1	Safety Notice	5
2	MDT 860 Hardware	6
2.1	Box Contents	6
2.2	Front Components	6
2.3	Back and Underside Components	7
3	Positioning the MDT 860 in a Vehicle	8
3.1	MDT 860 Suction-Mount	8
3.2	MDT 860 M3 Mounting Holes	8
4	Getting Started	9
4.1	Screens	9
4.2	Function Keys	13
5	Messaging	14
5.1	Receiving Messages	16
5.2	Reading Messages	16
5.3	Sending a Message	17
5.4	Deleting a Message	18
5.5	Reading and Managing Sent Messages	18
6	Driver Options	19
6.1	Introduction	19
6.2	Driver Options	19
7	Miscellaneous	23
8	Configuration	24
8.1	General	25
8.2	Display	25
8.3	Keypad	25
8.4	Buzzer	25
8.5	Font	25
8.6	Language	25
8.7	Status Bar	26
8.8	Notification	26
8.9	Main Menu	26
8.10	Inbox	27
8.11	Outbox	27
9	Diagnostics	28
10	Communication Test	29
11	Pop Ups	30
12	Specifications	31
	Appendix	32
	External Keyboard	32
	Memory Usage	32
	Using Multi-Tap Text Entry	32
	The Editor Screen	33
	Conditions of Sale and Warranty	34
	Contacts	35



# 1 Introduction

Thank you for purchasing this Navman MDT 860. We hope you enjoy your new OnlineAVL messaging terminal.

Whether your fleet operates in a city, across a country or a continent, the MDT 860 will provide efficient, cost effective and timely two-way text messages from the dashboard to the OnlineAVL application loaded on a PC at your office. The MDT 860 can send pre-programmed replies or outbound messages.

Navman welcomes your feedback. To contact us, please find our details in the Contacts section at the back of this user manual.

## 1.1 Safety Notice

**WARNING:** In a vehicle, it is your sole responsibility to place, secure and use the MDT 860 in a manner that will not cause accidents, personal injury or property damage. The user of this product is solely responsible for observing safe driving practices and for all use of this device. It is your responsibility to read and follow the vehicle mount installation instructions and to use the product in consistent with your government's laws and regulations. Consult the vehicle manual to ensure the mounting location is safe. It is your sole responsibility to adhere to the following safety instructions at all times:

- Do not operate the MDT 860 while driving or place the MDT 860 in a position that obstructs the driver's view.
- Do not mount the MDT 860 in a way that may be distracting or interfere with the safe operation of the vehicle, the deployment of airbags or other safety equipment.
- Do not leave the MDT 860 in view while your vehicle is unattended, especially in strong or direct sunlight.
- Do not use or handle the MDT 860 when it is hot; leave it to cool, out of direct sunlight.

Failure to adhere to these instructions may lead to serious personal injury, including death, or property damage. Navman disclaims all liability for use of the MDT 860 that contributes to injuries, death, property damage or violates law.

## 2 MDT 860 Hardware

### 2.1 Box Contents



MDT 860



Flexible mount



RJ45 cable



Keyboard adaptor cable (RJ25 -&gt; PS2)



Mounting Clip



User manual



Quickstart guide



Installation guide

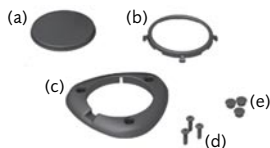

Hardware mounting kit:

- (a) Baseplate
- (b) Retainer ring
- (c) Screw plate
- (d) 3 x Screws
- (e) 3 x Screw caps

### 2.2 Front Components



	Component	Description
1	LCD Screen	Displays messages and menu options.
2	Function Keys	One touch navigation to menu options. Refer to section 4.2.
3	Power Button	Turn the MDT 860 display on and off.
4	Alpha Numeric Keys	Use to input numeric or textual information using multi-tap.
5	Accept / Enter Key	Use to select the highlighted item. Confirms a selection.
6	Cancel / Escape Key	Steps back 1 screen. Go to Main Menu – when held down. Rejects a selection.
7	4-way Cursor Key	▲ ▼ Use to navigate through the menus. ◀ ▶ Use to move the cursor on an edit screen. Use to select configuration items / values on the configuration screen.

## 2.3 Back and Underside Components



	Component	Description
1	Slide Bracket	Use to attach to the windshield suction mount.
2	RJ45 connectors	RS232 & RS485 serial ports.
3	RJ25 Connector	Keyboard port.

## 3 Positioning the MDT 860 in a Vehicle

There are three options provided for mounting the MDT 860:

1. Use the suction mounted, flexible, snap-lock bracket provided.
2. Panel mount the MDT 860 with the hardware mounting kit provided.
3. Attach to a Panavise bracket (Navman part number BK000025-G) or an alternative bracket using the M3 mounting holes in the backcase.

### 3.1 MDT 860 Suction-Mount

Follow these steps:

1. Attach the MDT 860 to the vehicle mount by matching the two slides on the stand to the corresponding slots on the back of the MDT 860 unit and slide together until they firmly latch into place.
2. Choose a position on the windshield that is clearly visible to the driver without obstructing the view of the road or any safety equipment ie airbags. Clean the surface thoroughly.
3. Press the suction cup firmly to the surface. Pull the lever down to seal the suction cup. The suction cup firmly anchors the vehicle mount.
4. Hold the vehicle mount base firmly and bend the stalk to adjust to a safe and easy viewing position.

### 3.2 MDT 860 M3 Mounting Holes

The holes (illustrated in the diagram below) can be used to attach the MDT 860 to a Panavise bracket or an alternative bracket.

Use the diagram below as a guide to insert M3 x 6 mm machine screws. Do not over tighten, as driving the M3 machine screws in too far may cause damage.

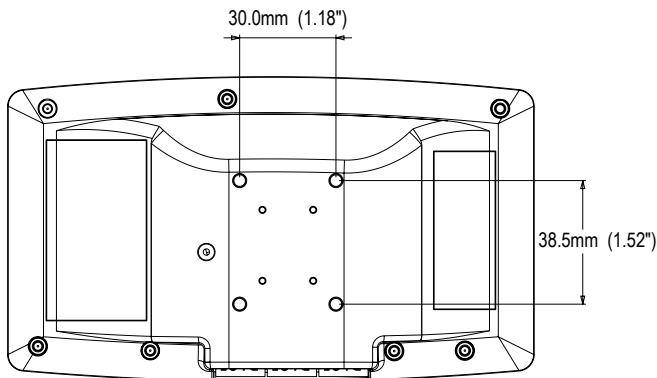

## 4 Getting Started

On installation or reset of the unit, the MDT 860 displays a *Start* screen that indicates the product name and software version. After a few seconds a *Legal Disclaimer* screen is displayed.

You must secure and use the MDT so as not to cause personal injury or property damage, or obstruct your view or vehicle safety equipment. Do not operate the MDT while driving. You are solely responsible for observing safe driving practices and for all use of the MDT. Press ACCEPT to continue.

Press ✓ (Accept) to open the *Main Menu* screen.

### 4.1 Screens

Two types of screens are used: a normal screen and a pop up screen.

#### Normal screen

Normal screens are used to display and to process the MDT 860 OnlineAVL application.

A normal screen makes use of the entire display and consists of three parts:

- Screen Title
- Screen Body
- Status Bar

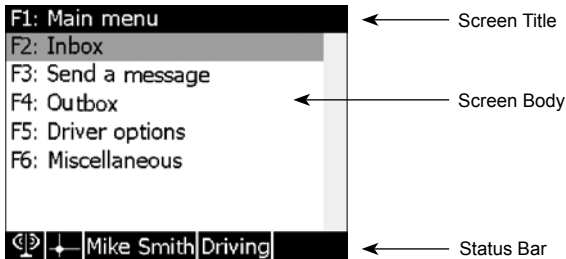

#### Screen title

The Screen Title identifies the screen. Some additional information related to the contents of the screen (body) may also be displayed on the title bar.

## Screen body

The Screen Body contains a particular type of information (menu, text, configuration or diagnostic).

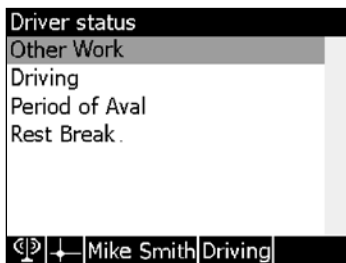

If the information to be displayed is larger than what the screen can display, a vertical scroll bar will appear on the right hand side and the screen can be scrolled.

Information that is entered or changed in an editable screen is preserved (even if a pop up screen is displayed) until the screen is closed or the MDT 860 is turned off/reset.





The size of the font used in the screen body area is user configurable. Refer to section 8.5 Font Size.





## Status bar

The Status bar displays continuously updated information related to the operation of the in-vehicle system. The status bar can be customised to display one or more items. Refer to section 8.7 Status Bar for a full list. Example of items:

- Current status of GPS (fix/no fix)
- Current status of the modem (online/offline)
- Current time
- Driver's name
- Inbox status (presence of unread text messages)

The Status bar will display information in icon format. The following icons are used:

Icons	Description
	The Halo Qube modem is Online.
	The Halo Qube modem is Offline.
	The Halo Qube has a valid GPS fix.
	The Halo Qube does not have a valid GPS fix.
	Indicates that there are unread messages.

	Indicates the status of the Inbox memory, from empty to full.
	Indicates the status of the Outbox memory, from empty to full.
	Indicates the status of the outgoing messages memory, from empty to full.
	Indicates that a Halo Qube is connected to the MDT 860.
	Indicates that an external keyboard is connected to the MDT 860.

## Pop up screen

Pop up screens are used to display out of order notifications about important events or warnings generated as a result of actions taken. Pop up screens require immediate attention and/or action. In most cases, a beep will sound when a pop up is displayed.

Most pop ups are blocking, i.e. pop ups must be actioned in order to be able to return to the previously opened screens. Non-blocking pop ups, such as notifications regarding restoration of cellular connection or GPS fix are shown for a few seconds only.

- A pop up screen is displayed over a normal screen and usually occupies only a part of the display.



**Note:** Pop up screens are not stacked. However, in some cases if an event requiring generation of a pop up arises while another pop up is shown on the screen, a beep will sound and the later pop up will be displayed after the previous one has been processed.

## Screen navigation

MDT 860 screens are accessed through menus.

Initially, when the device is powered up, a *Start* screen showing technical information about the hardware and firmware is displayed for five seconds. A legal disclaimer is displayed after this *Start* screen. The disclaimer remains displayed until ✓ is pressed, after which the main menu is displayed.

From the *Main Menu* screen, any single piece of information or control can be accessed via a series of menus. All successive screens opened by selecting items in the submenus are stacked. As a result, when traveling back up the menu structure (by closing the opened screens) all previously opened screens can be retrieved in the same state they were left.

Alternatively, to return directly to the *Main Menu* screen (where all opened screens will be automatically closed), press and hold the × key.

At all times, one item from the menu will be highlighted. To navigate through the menu, use the '4-way cursor key' to highlight the required item.

A highlighted item can be selected by pressing the ✓ key. Selecting an item will result in either another screen opening, or one or more opened screens closing.

## Main menu

The *Main Menu* screen is the starting screen in the series of menus. The following items are available:

- Inbox
- Send A Message
- Outbox
- Driver Options
- Miscellaneous



The availability of items on the *Main Menu* are access controlled. It is possible to configure the MDT 860 to display any of the items above. This configuration will be possible over the air from the OnlineAVL application or locally via the Configuration menu. Refer to section 8.9 *Main Menu*.

## 4.2 Function Keys

The Function Keys provide a 'one touch' navigation to the menu options.

Function Keys	Menu Option
F1	Main Menu
F2	Inbox
F3	Send a Message
F4	Outbox
F5	Driver Options
F6	Miscellaneous

**Note:** Regardless of the screen (excluding pop up screens) the MDT 860 is displaying at the time, selecting a function key will always transport the screen to the corresponding menu option as listed above, providing that the option selected has been enabled. Refer to section 8.9 *Main Menu*.

## 5 Messaging

Text messages are categorised into three distinct groups:

Group	Description
Received	Incoming messages received by the MDT 860.
Responses	Messages sent from the MDT 860 as responses to received message(s).
Originated	Messages created from the MDT 860, other than responses.

There are three separate entries in the *Main Menu* that give access to the text messaging functionality:

### Inbox

The *Inbox* shows a list of all messages received from the OnlineAVL application and stored in the MDT 860. Messages are shown in the order of their receipt, with the most recent message at the top.

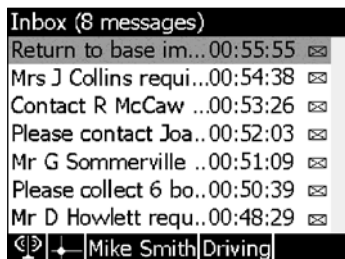

The following information in the *Inbox* is shown for each message, on a single line:

- First words of the message
- Time or date of reception (time only is given if the message has been received on the current day, otherwise date only is given).
- Message's current status.
  - New (unread)
  - Read
  - Replied

**Note:** When the *Inbox* is initially opened the highlighted message is dependant upon the *Inbox* settings. Refer to section 8.10 *Inbox*. The options available are:

- Top: The newest message
- Bottom: The oldest message
- Current: The message accessed most recently

## Send a message

Displays a complete list of options for sending a message from the MDT 860. The content of the screen is configurable and may contain a list of canned (pre-programmed) messages as well as a free form text message.



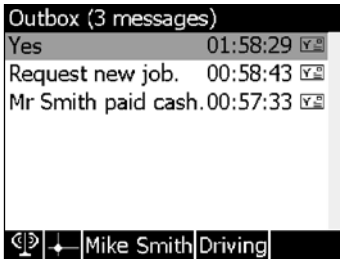

## Outbox

The *Outbox* shows a list of all messages sent from the MDT 860. Messages are shown in order of their sending, with the most recent message sent at the top.



The following information in the *Outbox* is shown for each message, on a single line:

- First words of the message
- Time or date of sending (time only is given if message has been sent on the current day, otherwise date only is given)
- Current status of the message
  -  Sent
  -  Delivered

## Additional notes on messages

- The MDT 860 can store hundreds of messages. A pop up screen is displayed to warn when the storage for a particular type of message is about to become full.
- If the message memory becomes full, the MDT 860 will not be able to receive an incoming message. The message will be rejected and an appropriate warning will be displayed.

## 5.1 Receiving Messages

When a new message is received by the MDT 860, a New Message pop up screen will be displayed, accompanied by a beeping signal, regardless of what screen is being viewed.

Press ✓ to open the *Inbox* screen.



**Note:** If a new message is received while there are unsaved changes on the screen (e.g. while editing a reply) a warning will be issued.

Selecting Cancel will close the new message pop up screen and the message can be viewed later from the *Inbox* menu.

## 5.2 Reading Messages

The Screen Title of the *Read Message* screen displays the time that the message was sent and the time that the message was received at the MDT 860.



Press ✓ to reply to the message. See section 5.3 Sending a Message.

## 5.3 Sending a Message

A message can be sent by replying to an incoming message or sending an original (created) message.

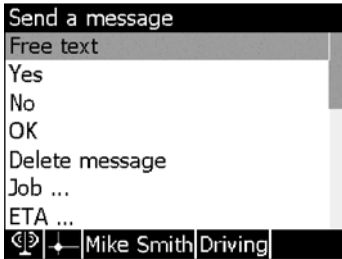

**Notes:** Canned messages and the message folders are set up by the Fleet Operator.

The following rules apply to all messages sent from the MDT 860:

- Both free-text and canned messages (editable and non-editable) can be sent from the MDT 860
- Editable canned messages may contain a field that can be edited before sending.
- Text messaging operates on vehicle-by-vehicle (MDT by MDT) basis, i.e. there are no special provisions for text messaging on driver-by-driver basis

### Sending an original message

Select *Send A Message* from the *Main Menu* (or press F3). The *Send A Message* screen will be displayed. Select either a canned message or the free form text message. To enter a free form text message use either the multi-tap keypad or an external keyboard. Refer to section Appendix and see External Keyboard.

### Replying to received messages

Select *Inbox* from the *Main Menu* (or press F2) and highlight the message to reply to.

Press ✓ to display the *Process Message* screen.

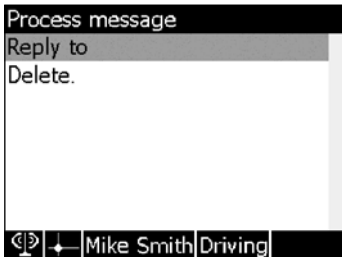

Select Reply To The *Send A Message* screen will be displayed.

Select either a canned message or the free form text message. To enter a free form text message use either the multi-tap keypad or an external keyboard. Refer to section Appendix and see External Keyboard.

## 5.4 Deleting a Message

Select *Inbox* from the *Main Menu* (or press F2) and highlight the message to delete.

Press ✓ to display the *Process Message* screen.

Select Delete from the menu to delete the message from the *Inbox*. To delete all the messages in the *Inbox*, refer to section 8.10 *Inbox*.

A notification is sent to the OnlineAVL application to notify users the message has been deleted.

**Note:** When deleting a message, a pop up screen confirming this action will be displayed to ensure messages are not deleted in error.

## 5.5 Reading and Managing Sent Messages

To read replies that have been sent in response to received messages, select *Inbox* (or press F2).

Use the ▲ and ▼ on the 4-way cursor key to select the message.

Press ✓ to display the *Previous Replies* screen. Select either Delete or Resend.

To read sent messages, select *Outbox* (or press F4).

Use the ▲ and ▼ on the 4-way cursor key to select the message.

Press ✓ again to display the *Process Previous Message* screen to either Delete or Resend the message.

## 6 Driver Options

### 6.1 Introduction

*Driver Options* contains the functionality to support the Driver ID and Driver Hours features.

**Note:** These features are enabled over the air from the OnlineAVL application.

When either the Driver ID or Driver Hours features are enabled, in order to use the MDT 860 the driver needs to be logged on.

Logging on consists of entering a Personal Identification Number (PIN) into the MDT 860, which is then checked over the air by the OnlineAVL server. A successful PIN results in the driver's name being sent by the server to the MDT 860. If no match is found for the entered PIN, the log on fails and the MDT 860 continues to beep until a correct log on is recorded.

- The requirement for the driver to be logged on in order to access all services of the system is configurable from the OnlineAVL application
- When a vehicle with no-one logged on is detected to be in use (ignition has been turned on), the MDT 860 will beep until a logon is confirmed

The Driver Hours feature makes it possible to monitor drivers' activities and to record their working time as well as the duration of breaks taken. This, in turn, makes it possible to monitor and to report driver's compliance with relevant industry and health and safety regulations.

### 6.2 Driver Options

Select *Driver Options* from the *Main Menu* (or press F5) to display a menu with the following options:

Option	Description
Log on or Log off	Depending upon the current state, either log on or log off.
Driver Status	Select to view a list of available driver statuses.
Working time	Select Working time to display the total time the driver has spent in "working" state since log on. Working time is cleared when log off occurs.

## How to log on

The *Driver ID Log On* screen will appear on the MDT 860 immediately after the ignition is turned on.

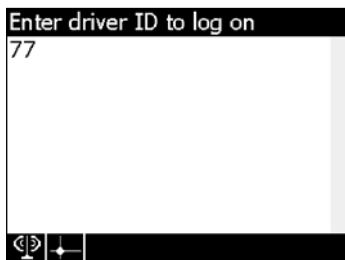

Using the numeric keypad enter the complete Driver PIN.

Press ✓ to confirm the Driver PIN. The MDT 860 will then send the PIN number back to the OnlineAVL application for checking. Confirmation may take a few minutes depending on cellular network coverage.

## If the vehicle is out of coverage

If the vehicle is out of cellular coverage when inserting the Driver PIN, the Halo Qube tracking device will store the information and will send it when the vehicle is back in cellular coverage.

## If a CORRECT DRIVER PIN has been entered

The *Driver ID Status* pop up screen will appear with details of the driver's name.

Press any key on the MDT 860 to exit the screen.



## If an INCORRECT DRIVER PIN has been entered

The *Driver ID Status* pop up screen will appear with 'Log on Failed'.

Press the × key to exit the screen.

The *Driver ID Log on* screen will reappear to request a valid log on.

## If a PIN number that is ALREADY IN USE by another driver has been entered

The *Driver ID Status* pop up screen will appear with 'Log on Failed! You are already logged on'.

Press any key on the MDT 860 to exit the screen.

The *Driver ID Log On* screen will reappear to request a valid log on. Contact your office immediately to ask the Fleet Operator to re-confirm the Driver PIN and/or check why the Driver PIN is in use.

## How to log off

Select *Driver Options* from the *Main Menu* (or press F5).

Select Log off from the menu.

The *Driver ID Log Off* screen will appear.

Press ✓ to confirm log off OR press the × key to cancel the action.

**If Driver Status\* is activated**, the driver must select a status before log off can occur.

\*The Driver Status feature is only visible on the MDT 860 if it has been activated. This feature is not available in all the regions.

**Note:** If the Driver ID is logged off, but the vehicle's ignition has not been turned off, the *Driver ID Log On* screen will reappear requesting a valid log on.

## How to change driver status\*

Select *Driver Options* from the *Main Menu* (or press F5).

Select Driver Status from the menu.

Use the 4-way cursor key to select the correct status.

Once highlighted press ✓ to confirm the Driver Status.

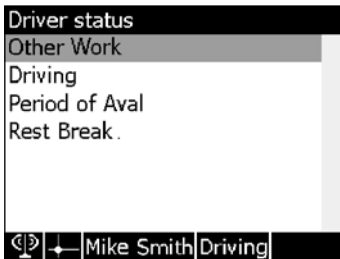

\*The Driver Status feature is only visible on the MDT 860 if it has been activated. This feature is not available in all regions.

## If the MDT 860 is beeping

The MDT 860 will beep to remind that a log on with a Driver PIN is required. The beeping can be stopped by entering a correct Driver PIN. If a Driver PIN has not been assigned and the MDT 860 is beeping, contact your office immediately.

## 7 Miscellaneous

Select *Miscellaneous* from the *Main Menu* screen (or press F6) to access the *Miscellaneous* screen.

The *Miscellaneous* menu provides access to three sub-menus:

- Configuration
- Diagnostics
- Communication Test

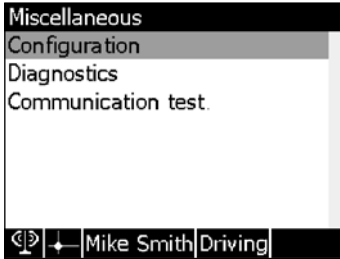

## 8 Configuration

The *Configuration Menu* screen provides access to menu options that allow users to configure various MDT 860 settings.



The following MDT 860 settings are available:

- General
- Display
- Keypad
- Buzzer
- Font Size
- Language
- Status Bar
- Notifications
- Main Menu
- Inbox
- Outbox

Use the 4-way cursor key to select an MDT 860 setting. Press the ✓ key to confirm selection.

Settings for individual MDT 860 settings can be modified by using the ◀ and ▶ on the 4-way cursor key. As a general rule, a short press on the ◀ or ▶ key will make the value increase or decrease by a unit. A continuous press on the ◀ or ▶ key will make the value increase or decrease by several units. All exceptions to this rule are given in the paragraphs detailing the individual settings (refer to section 8.1 General to 8.11 Outbox).

**Note:** All changes to settings take effect in real time.

To ACCEPT configuration settings, press the ✓ key to:

Options:

- Save
- Restore defaults
- Restore defaults and save
- Cancel

Press the × key to return the screen to the Configuration Menu and restore the previous values.

## 8.1 General

The MDT 860 turn-off time (time the MDT 860 turns off after ignition has been switched off). Range: 1 – 255 minutes or infinite.

## 8.2 Display

- Contrast. Range: 0 – 100%
- Backlight intensity. Range: 0 – 100%
- Backlight timeout (time the backlight is turned off after ignition has been switched off)  
Range: 1 – 255 minutes or infinite

## 8.3 Keypad

- Multi-tap timeout (length of time before a multi-tap character is automatically accepted. Refer to the Appendix and see Using Multi-Tap Text Entry). Range: 0.1 – 5 seconds
- Backlight intensity. Range: 0 – 100%

## 8.4 Buzzer

Three settings are available for the keypad key-press tone (beep):

- Pitch. Range: 100 – 8000 Hz. (**Note:** A continuous press on the ◀ or ▶ key will result in a large increase or decrease of the pitch)
- Duration. Range: 1 – 255 milliseconds
- Volume. Range: 0 – 100%

## 8.5 Font size

The following font sizes are available for the screen body:

- Tiny (8 lines of text per screen body)
- Small (7 lines of text per screen body)
- Medium (6 lines of text per screen body)
- Large (5 lines of text per screen body)

Font sizes can be selected by using the ◀ and ▶ cursor keys. Press the ✓ key to accept the selection.

## 8.6 Language

The following languages are available:

- English
- French

Use the ◀ and ▶ cursor keys to select a language. Press the ✓ key to accept the selection.

**Note:** The Language settings apply to:

- Fixed elements of the screens (titles, menus, pop ups, etc.)
- Keypad multi-tap character subsets

Language setting does not apply to messages received at or sent from the MDT 860.

## 8.7 Status Bar

The status bar can be customised to display the following information:

- Current status of GPS (fix/no fix)
- Current status of the modem (online/offline)
- Current time
- Current date
- Driver's name
- Driver's status
- Inbox status (presence of unread text messages)
- Qube status (Halo Qube present)
- Keyboard status (external keyboard present)
- Inbox memory usage
- Outbox memory usage
- Incoming/Outgoing messages memory usage

Use the **➤** and **➤** cursor key to select or deselect (Yes or No) the required information, respectively.

**Note:** The Status bar configuration screen settings are applied in real-time, so the selection can be viewed at the time of changing before accepting or canceling the action.

## 8.8 Notifications

Use to set up a subset of active real-time notifications. The following notifications can be enabled or disabled:

- Change of GPS status
- Modem change of state
- Memory overflow warnings

Use the **➤** and **➤** cursor keys to select or deselect (Yes or No) the required information.

## 8.9 Main Menu

The Main menu can be customised to enable or disable the following options:

- Inbox
- Send A Message
- Outbox
- Driver Options

Use the **➤** and **➤** cursor keys to select or deselect (Yes or No) the required options.

## 8.10 Inbox

The following settings are available:

- Message focus (bottom, current, top). Use the ► and ◀ cursor key to select the required option
- Automatic saving of responses. Use the ► and ◀ cursor key to enable or disable (Yes or No) the required option
- Threshold (percentage of the full capacity = 100%) above which warnings need to be issued regarding the usage of Inbox memory. Range: 0 – 100%
- Delete all messages. Press ✓ to delete all the messages in the *Inbox*
- Delete all stored responses. Press ✓ to delete

**Note:** When deleting messages, a pop up screen confirming this action will be displayed to ensure the messages are not deleted in error.

## 8.11 Outbox

The following settings are available:

- Automatic saving of originated messages. Use the ► and ◀ cursor keys to enable or disable (Yes or No) the required option
- Action to perform on originated messages memory overflow: stop storing new messages or overwrite the oldest message. Use the ► and ◀ cursor keys to select the required option
- Threshold (percentage of the full capacity = 100%) above which warnings need to be issued regarding the usage of Outbox memory. Range: 0 – 100%
- Delete all stored originated messages. Press ✓ to delete

**Note:** When deleting messages, a pop up screen confirming this action will be displayed to ensure the messages are not deleted in error.

## 9 Diagnostics

The following items are displayed:

- Voltage of power supply
- Temperature
- GPS fix status
- Modem status
- AVL ID
- MDT 860 firmware version
- Halo Qube firmware version
- Ignition Status

Diagnostics	
Voltage [V]	14.37
Temperature [°C]	30
GPS fix	No
Modem	Online
AVLID	352884000057340
MDT version	2.1.0.35,1
Qube version	n/a
📶 ↕ Mike Smith Driving	

## 10 Communication Test

Select Communication Test to perform an end-to-end communication test between the MDT 860 and the OnlineAVL server. A message will be received on the MDT 860 if the communication link works correctly.

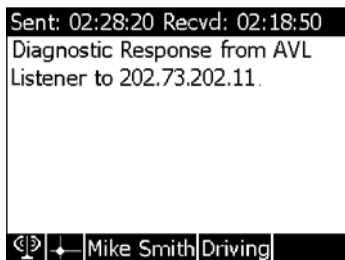

# 11 Pop Ups

All real-time notifications are displayed as Pop up screens. A tone may accompany some pop up screens.

Example of a Pop Up screen.

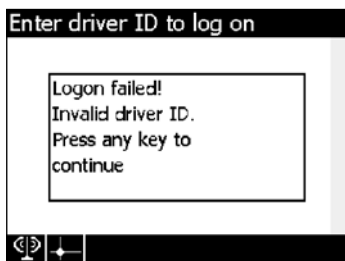

The following external (activated by the OnlineAVL Server) notifications are available:

- Driver ID disabled! Press any key to continue
- Driver status disabled. Press any key to continue
- 'xxx' has been logged on. Press any key to continue
- Logon failed! Invalid driver ID. Press any key to continue
- Logon failed! Driver logged on 'xxx'. Press any key to continue
- Server logged you off! Press any key to continue
- Log on now! Press any key to continue
- Unsaved changes! Press ACCEPT (✓) to open the Inbox or Press CANCEL (✗) to continue previous operation
- Confirm delete. Press ACCEPT (✓) to delete or Press CANCEL (✗) to cancel
- You have 'xxx' new message(s). Press ACCEPT (✓) to open the Inbox or CANCEL (✗) to exit

**Note:** The 'xxx' represents 'drivers name', 'vehicle's ID' or 'number of messages'

The external notifications cannot be disabled.

The following internal (activated by the MDT 860 device) notifications are available:

- Modem connected
- Modem disconnected
- GPS fix lost
- GPS fix recovered
- Inbox is nearly full. Please delete some messages
- Outbox is nearly full. Please delete some messages
- Incoming message rejected! Please delete some messages. Press ACCEPT (✓) to open the Inbox or CANCEL (✗) to exist
- Operation cannot be completed. No contact with the server. Please try later. Press any key to continue
- Reply cannot be sent. Inbox is full. Please delete some messages. Press any key to continue
- Message cannot be sent. Outbox is full. Please delete some messages. Press any key to continue

Internal notifications, with the exception of messages memory overflows, are user configurable and can be disabled.

# 12 Specifications

## Physical:

- Size: 165mm x 95mm x 30mm
- Weight: 233g

## Display:

- 58mm x 77mm
- White LED backlight, user selectable level
- 320 x 240 pixels, 4 grey levels

## Memory:

- 10KB RAM
- 32KB EEPROM
- 1664KB Flash as 2 banks
- 256KB battery-backed SRAM, as 2 banks

## Keypad:

- 21 keys with backlighting
- 4 way cursor key with backlighting

## External Interface:

- Two RJ45 connectors (Power and RS232)
- International PC AT keyboard interface via RJ25 connector. Keyboard adaptor cable RJ25 to PS/2 supplied

## Electrical

- +8 to +42VDC
- Operating: 130mA@12V, DC 70mA@24V DC (backlight on)
- Standby: 25mA@12V DC, 15mA@24V DC (LCD and backlight off)

# Appendix

## External Keyboard

The external keyboard is an optional device. When connected, it complements the in-built keypad.

**Note:**

- Some of the keys are not supported (e.g. Tab, Insert)
- There is no equivalent to the Power (•) key
- The soft keys (1-6) are mapped onto the function keys (F1 – F6, respectively)
- The Accept key (insert symbol of the tick in brackets) is mapped onto the Enter key, except in the editor screen
- The Cancel key (insert symbol of the cross) is mapped onto the Esc key

## Memory Usage



The following should be noted with regards to memory storage of OnlineAVL messages:

- Messages awaiting transmission are stored in a buffer which, in certain situations (vehicle out of cellular coverage for prolonged time), may overflow. If this happens, an appropriate notification is issued. However, no newly generated messages will be stored for sending (they will be lost).
- When the storage for the Inbox becomes full, no new messages are accepted and a warning displays every time a new message arrives.

## Using Multi-Tap Text Entry

- Multi-tap is only available for the alpha numeric keys (0 – 9).
- Two subsets of special characters have been implemented for keys 0 and 1. These include punctuation, currency and other symbols.
- Multi-tap characters are language-dependent, i.e. any language-specific (accented, special) characters are only available for the language in question.
- In multi-tap mode, the subset of characters available for the currently used key is displayed over the status bar with the current character highlighted.
- Multi-tap timeout (length of time before a multi-tap character is automatically accepted) is user-configurable. Refer to section 8.3 Keypad.

How to enter multi-tap text:

- Press a key one or more times until the required character appears on the screen (e.g. to select the character 'M', press the  key 4 times.  
To accept the selected character, use one of the following options:
  - Pause for a short while OR
  - Press the  key on the 4-way cursor key OR
  - Continue to enter the next character using a different key
- To select and accept a numeric character, press the key once with a continuous pause.

- To delete one or more characters before the cursor, press with a short pause the × button one or more times. **Note:** Do not use a continuous pause on the × button, as this will return the screen to the *Main Menu*.

## The Editor screen

The Editor screen is used for editing free form text messages.

- Use the 4-way cursor key ► ◀ ▲ ▼ to move the cursor around the screen.
- Press ✓ to send the message (or F12 if using an external keyboard).
- To delete all the text in the message, place the cursor at the beginning of the text and press × (⬅) Backspace if using an external keyboard).

# Conditions of Sale and Warranty

## A. Conditions of Sale

**Important Notice**

Some of the following terms and conditions vary from country to country. Please check with your Navman dealer from whom you purchased your product.

Except to the extent otherwise required by the laws of the country in which the accompanying product ("the product") is sold the manufacturer of the product Navman NZ ("Navman") - has no liability in respect of the product beyond the warranty hereunder provided. Where liability may not be excluded but may be limited to repair or replacement or the supply of equivalent goods or for the payment of the cost of replacing the goods or of acquiring equivalent goods, liability is so limited.

## B. Manufacturers warranty

Warranty Period - 1 year from the date of purchase.

Extent of warranty - Subject to the following conditions Navman will rectify any defect occurring in the product of which notice in writing is received by Navman or its approved distributor within the Warranty Period.

Conditions:

1. Repairs may only be carried out by a Service Centre approved by Navman.
2. Repairs as above will be carried out at no cost to the owner subject to these conditions.
3. The cost of returning the goods to an approved dealer shall be met by the owner.
4. Warranty does not extend to accessories or defects or injuries caused or resulting from causes not attributable to faulty parts or the manufacturer of the product including, but not limited to, defect or injuries caused by or resulting from misuse, abuse, neglect, accidental damage, incorrect installation, water damage, use of consumables other than those approved by Navman or any alterations to the product not approved by Navman.
5. No warranty claim accepted without sales documentation.
6. Navman may, at its discretion, replace the product instead of repairing it.

## C. Acceptance of Conditions of Sale

In consideration of this warranty the purchaser accepts the limitations of liability as set out in the conditions of sale.

## Contacts

<p><b>Navman Australia</b> Suite 2, 408 Victoria Rd PO Box 479 Gladesville NSW 2111 AUSTRALIA Tel: 02 9879 9000 (option 3) Email: wdgaussupport@navman.com.au</p>	<p><b>Navman NZ</b> 7-21 Kawana St, Northcote PO Box 68 155 Newton Auckland NEW ZEALAND Tel: 0800 GPS FLEET (0800 477 353) Email: wirelessnzsupport@navman.com</p>
<p><b>Navman UK</b> Innovation Centre 2 Keele University Science Park Keele, Staffordshire, ST5 5NH UNITED KINGDOM Tel: (0) 8454 561 660 Fax: (0) 1782 557 979 Email: support@navmanwireless.co.uk Website: www.navmanwireless.co.uk</p>	<p><b>Navman US</b> 150 N. Field Drive Suite 325 Lake Forest, IL, 60045 UNITED STATES OF AMERICA Tel: 847-735-4626 Fax: 847-735-4696 Email: wirelessussupport@navman.com</p>

NAVMAN DISCLAIM ALL LIABILITY FOR ANY USE OF THIS PRODUCT IN A WAY THAT MAY CAUSE ACCIDENTS, DAMAGE OR VIOLATE THE LAW.

## Compliance

This device complies with part 15 of the FCC Rules. Operation is subject to the following two conditions: (1) This device may not cause harmful interference, and (2) this device must accept any interference received, including interference that may cause undesired operation.

## Copyright

© 2007 Brunswick New Technologies Asia Pte Limited. Navman™ is a registered trademark of Brunswick New Technologies Asia Pte Limited and is used under licence by Navman New Zealand. All rights reserved.

Halo™ and OnlineAVL™ are registered trademarks of Brunswick New Technologies Asia Pte Limited and are used under licence by Navman New Zealand. All rights reserved.

Adobe Reader is a registered trademark of Adobe Systems Incorporated. All rights reserved.

All other trademarks and registrations are the property of their respective owners.

Published in New Zealand.

MN000498A

Lon 174° 44.480'E



Lat 36° 48.422'S